



Operating and installation guide for the *motoscope light*

Thank you very much for purchasing a high quality product by *motogadget*.

Please read the following information and recommendations completely and follow these instructions during installation and use of the instrument. For damages and defects that result due to negligence, or failure to follow the instruction and installation guide exist no rights to claim guarantee and liability by *motogadget*.

Contact:

motogadget
Simplonstr. 59
10245 Berlin

Tel. 030-27 59 19 20
Fax 030-27 59 19 22

www.motogadget.de
info@motogadget.de

Version 1.13
© Copyright and all other rights by motogadget, Berlin 2007

Table of contents

1	Review of delivery	4
2	Exclusion of liability	4
2.1	Duty of registration (depends on the laws of the customers country / state)	4
3	Technical data	4
3.1	Summary of functions	5
4	Preparations for installing and connecting the instrument	5
4.1	Necessary knowledge and abilities	5
4.2	Needed materials for installing and connecting the instrument	5
5	Quick start	6
6	General safety instructions	6
7	Installation of the <i>motoscope light</i>	6
8	Connection of the <i>motoscope light</i> and the wiring harness	7
8.1	Cable routing recommendations	7
8.1.1	Cable colours	7
8.2	Battery and voltage supply	7
9	Installation and connection of sensors and the pushbutton	7
9.1	The pushbutton	7
9.2	Rev counter sensor cable	7
9.3	Installation and connection of the speedometer sensor	8
10	Putting the instrument into the initial operation phase	8
11	Operation and use of the instrument	8
11.1	General operation instructions	8
11.2	LED indications	8
11.2.1	Rev. counter indications in rpm by the LED band	8
11.2.2	The adjusted revs. limit ("red area")	8
11.3	The LCD display	8
11.3.1	Selection of different indications	8
11.3.2	The speed indication (in mph or km/h)	9
11.3.3	The daily-odometer-counter (mi or km)	9
11.3.4	The total-odometer-reading (mi or km)	9
11.3.5	Time counter for the current ride (hh:mm:ss)	9
11.3.6	Vehicle system voltage (V)	9
11.3.7	Current acceleration (m/s ²)	9
11.3.8	Speed average (mph or km/h)	9
11.3.9	Indication of rev./min on the LCD (rpm)	9
11.3.10	Time counting from 0-100 km/h or 0-60 mph (sec)	9
11.3.11	Storing of maximum speed (mph or km/h)	9
11.3.12	Storing of maximum rev./min (in rpm)	9
11.3.13	Maximum acceleration (m/s ²)	9
11.3.14	Maximum deceleration (brake test) (m/s ²)	10
11.3.15	The gear position indicator (default setting is "off")	10
11.4	Resetting of measurements	10
12	The Set-up	10
12.1	The sub-period MENU	10
12.2	The sub-period LED	10
12.3	The sub-period LCD	11
12.4	The sub-period PARAM	11
12.5	The sub-period FLASH	12
12.6	The sub-period RESET	12
13	Cleaning of the instrument	13
14	Safety instructions	13
15	Trouble shooting	13
15.1	After the installation	13
15.2	Malfunctions in general	13
16	Appendix	14
16.1	EG conformity explanation (CE)	14
16.2	Terminal locations and colours of the connecting cables	15
16.3	General overview of operations by using the pushbutton	16

1 Review of delivery

All products from *motogadget* are checked functionally and are in faultless condition before they are dispatched. Please check the received goods immediately for possible transport damages. If damages or other deficiencies should exist, please contact us immediately. In this regard we refer to our general terms of business and delivery, which are published under www.motogadget.com. Should a return of the received delivery be agreed, please note that we only take back goods in the original packing. The instrument and its accessories must be returned within the legal period of time and without any traces of use. We do not assume any liability for returns which are insufficiently insured or packed.

2 Exclusion of liability

Important: *motogadget* accepts no liability for damage to any part of its products resulting from incorrect installation or incorrect usage.

Housings of instruments and all other delivered parts (i.e. sensors) **must not be opened or dismantled**. In case of offence all claims of guarantee become invalid. The use of the delivered instruments, sensors and accessory parts for racing or other competitions, as well as all uses that do not correspond to the recommended application renders all claims of guarantee invalid. *motogadget* takes no liability for direct or indirect damages or following damages of all kinds that result from the use, installation or connection of the instrument, the sensors or other delivered equipment. This exclusion of liability particularly includes damages to persons, material losses and financial damages. The use of the motoscope light and all of its accessory parts in areas of public traffic is done at own risk.

2.1 Duty of registration (depends on the laws of the customers country / state)

The **motoscope light** is not registration-obligatory if used in addition to a registered speedometer. If you want to use it as a single instrument without any other speedometer in areas of public traffic the instrument has to be treated according to the laws of country concerned (for example: legal check by an official authority and registration in the vehicle papers). The users of the instrument are personally responsible for complying with all relevant laws in the countries concerned.

The users are particularly responsible for correct determinations and adjustments according to the tire circumference and the installation of the dry reed contact as well as for the correct input of the determined data that control the speedometer.

3 Technical data

length, width, height	121 x 57 x 30 mm (without cable fitting)
weight of the <i>motoscope light</i>	ca. 250 g (instrument only)
fastening bores	3 x M4 thread bores
reception of current	200 – max. 500 mA (load-dependent)
operating voltage	9 – 18V DC
ambient temperature range	-15° ... + 50°C
stockroom temperature	-20° ... + 70°C

3.1 Summary of functions

Function	Measurement range
Rev. counter as LED band	0 -10,000 rpm or 0 -14,000 rpm
Speedometer	0-350 km/h or mph
Daily odometer (mileage recorder)	Up to 999.99 km or Mi
Total odometer (mileage recorder, adjustable)	to 250,000 km or Mi
Running-time display for the current ride (stopwatch)	0 - 99:99:99 H: m: s
Optical limits adjusting for engine speed (red warning LED)	0 -10,000 rpm or 0 -14,000 rpm
Vehicle system voltage	9.0 -- 18.0 V
Present acceleration	15.0 (-)-15.0 m/s ²
Average speed	0-350 km/h or mph
Rev. counter on LCD	0 -14,000 rpm
Time measurement from 0-100 km/h (maximum value stored)	0.0 -- 99.9 sec.
Maximum speed (maximum value stored)	0-350 km/h or mph
Maximum engine speed (maximum value stored)	0 -14,000 rpm
Max. positive acceleration (maximum value stored)	0.0 -- 15.0 m/s ²
Max. negative acceleration (maximum value stored)	0.0 -- (-15.0) m/s ²
Gear position indicator	1 to 6 gears
Exit for an external gear shift light.	Engine speed value adjustable

4 Preparations for installing and connecting the instrument

4.1 Necessary knowledge and abilities

Installing and connecting the *motoscope light* and its additional equipment requires no special knowledge and abilities if exact attention is paid to the following installation guide. The *motoscope light* can be installed on a wide range of different vehicles with different specifications and equipment. Thus, it is not possible to cover all special cases within this description. In cases of doubt, please use the offered information on our web site (support, FAQ). If a self-installation of the *motoscope light* and its equipment still seems to be too complicated, we recommend installation by a professional expert.

4.2 Needed materials for installing and connecting the instrument

The *motoscope light* is universally usable and made for a wide range of vehicles. Therefore, **additional materials** might be necessary in order to install the instrument to an individual vehicle. Such materials may be:

- a holding bracket for the instrument and fitting screws
- a mounting bracket for the speedometer sensor and for the pushbutton
- a pushbutton
- cables or cable extensions for the voltage supply and other connections
- further assembly materials like cable ties, plug connectors, shrink-hose, soldering iron, soldering tin

Tip: The headlight-flasher-switch of your vehicle can also be used as an alternative to the delivered non-locking switch.

If you don't want to use our universal instrument holding bracket we recommend the use of a self-made sturdy metal plate of about 3 mm thickness when made of aluminium.

A **mounting bracket** for the speedometer sensor is not part of the scope of delivery, because its design depends from the place of installation. It has to be made from sufficiently solid material individually for each vehicle.

The use of wiring diagrams for the vehicle concerned is also recommended.

5 Quick start

This section provides a guide to quick installation and connection of the *motoscope light*

- a) Make sure that you have all necessary materials and tools available before starting the installation. Such materials are: an instrument mounting bracket, a pushbutton, fitting screws and nuts, screw adhesive (medium-strength), cables, cable ties, plug connectors, shrink-hoses and soldering tin. Necessary tools are: screwdrivers, wrenches, an Allen key for M3 metric Allen screws, a side cutter, small pliers, soldering iron, a voltage indicator and a crimping tool.
- b) Make sure you have the wiring harness diagram of your vehicle and the terminal location plan of the *motoscope light* (see appendix)
- c) Choose suitable positions for installing the *motoscope light* and the speedometer sensor. Select a point to which the cables will be routed in order to connect the *motoscope light*, the speedometer sensor and the pushbutton. Cut and drill the *motogadget* mounting bracket for best fit or construct your own bracket. Design and make a mounting bracket for the speedometer sensor switch and attach it to the point you have selected.
- d) Mount the instrument and sensor on the vehicle.
- e) Locate “switched plus” on the wiring harness of the vehicle by using a voltage indication device. “Switched plus” means current must not flow until electric power is switched “on”.
- f) Remove the ground cable from battery terminal.
- g) Look for the negative terminal of **one** ignition coil (primary circuit!) and route a cable from this point to the terminal point you have chosen in stage c).
(Attention: In case of a genuine CDI ignition the positive terminal of the ignition coil must be used! In such a case, please read the corresponding chapters under "CDI ignition".)
Route cables from the voltage supply, the speed sensor, and pushbutton to their chosen location. Then connect the cables according to the circuit diagram provided in the appendix.
- h) Re-connect the vehicle battery and turn the voltage supply “on”.
- i) Navigate to the setup menu (see Chapter 12) and adjust all necessary parameters for engine speed, the rev. counter scale and the speedometer.
- j) Start the engine and watch the rev. counter. If it works correctly, ride carefully and slowly for a while and check the speedometer for plausibility. If you do not detect any problems regarding the electrical or mechanical functioning of the instrument and the vehicle itself, continue the test ride.

6 General safety instructions

- For safety reasons the vehicle **battery must be disconnected** prior to the installation.
- Take particular care that all delivered parts are fastened securely to your vehicle. This is extremely important for your own and other peoples' safety.
- Make sure that your vehicle is equipped with **interference suppressing spark plugs and connector cables!**
Use of the *motoscope light* with non-suppressed ignition systems can lead to serious damage to the device!

7 Installation of the *motoscope light*

To ensure correct fastening two metric fastening screws must be used. In order to avoid distortions of the threaded bores, the fastening bolts must be screwed into the instrument housing to a minimum depth of 3 mm and a maximum depth of 5 mm. It is therefore important to select screws appropriate to the thickness of the used mounting bracket. We also recommend the use of additional washers and screw adhesive (e.g. Loctite medium-strength). Furthermore, the **maximum torque** applied to the M4 fastening screws must not exceed **8 Nm**.

8 Connection of the *motoscope light* and the wiring harness

8.1 Cable routing recommendations

Before routing cables look for suitable cable paths. The cables should be as far away as possible from hot parts of the engine. Look for a suitable place for the respective cables to meet with their plugs and for the plugs to be connected with one another. This is usually in the headlight housing or somewhere below the gas tank. Make sure you take note of the required lengths of cables before cutting them for best fit. It is important here to consider the full lock of the handlebars as well as the front and rear wheel travel. All cables should be routed free of kinks and should not be subject to any tension. In addition, the cables have to be properly isolated, especially in places where mechanical wear can take place. For fastening the cables we recommend cable ties of synthetic material.

8.1.1 Cable colours

<i>motoscope light</i>		
Cable colour	Function	Connection
Red	Voltage supply	Plus (+) switched and 5A fused voltage from the wiring harness of the vehicle
Black	Ground connection	Minus (-) (ground of the vehicle)
Yellow	Signal cable of the rev. counter	Goes to the negative pole (clamp 1 or -) at one ignition coil. In case of a CDI-Ignition use the positive pole of the ignition coil. !Important! This cable must not be connected to the high-tension system of the ignition!
Orange	Cable for connecting the <i>motoscope light</i> to the speedometer sensor	Leads to the signal cable of the OEM speed sensor, or delivered sensor that switched to +12V
Green	cable for the pushbutton	Leads to the pushbutton that switches to earth
Brown	Exit for the gear shift light	Leads to an external gear shift light

8.2 Battery and voltage supply

The Motoscope require **switched plus** for the voltage supply. That means electrical power will flow if ignition lock is switched "on". The *motoscope* can operate in a voltage range from 9 V to 18 V DC. Operating the instrument without a battery, for example, using a direct connection to the vehicle's generator is not envisaged or recommended! Please ensure that the polarity of the voltage supply is correct.

Attention! The minimal supply cable width is 0,75mm². You **must** fuse the +12V power supply cable with a 5A fuse. If device will be use without fuse, damage at the connecting cable or the *motoscope* itself can cause a shortcut and a cable fire. **There may be risk of your life!** Make sure you are capable to connect the instrument properly. If you are not sure, let the shop do the job!

9 Installation and connection of sensors and the pushbutton

9.1 The pushbutton

To operate the instrument a pushbutton is to be connected. Therefore connect one of its terminals with the green cable of the *motoscope light* and the other one with earth (-). Polarity is not relevant (see diagram in chapter 16.1).

9.2 Rev counter sensor cable

The rev. counter sensor cable is yellow. It transmits the signals from the ignition to the device. Connect the yellow cable to the negative terminal (-) of one ignition coil or to the corresponding terminal of the ignition box [clamp 1 or earth]. In the case of existing rev counter output, connect the yellow cable directly with this output cable.

Important: This cable must not be connected to the high voltage output of the ignition system!

Attention: In case of a CDI ignition, the positive pole of the ignition coil must be connected!

9.3 Installation and connection of the speedometer sensor

The delivered speedometer sensor is a dry reed contact, which is triggered by a magnetic field. Therefore, the delivered magnet must be attached to the wheel with the contained epoxy glue. The speedometer sensor has to be attached to the vehicle by using a self made holding bracket. The sensor tip has to be fastened parallel to the magnet's surface. The gap between the magnet and the sensor must not exceed 5 mm and the sensor must not touch the magnet or any other rotating parts. The sensor holding bracket has to be made sufficiently stable in order to prevent any distance changes during any driving situations. The maximum mounting torque of the sensor nuts is 1,6 Nm. For secure mounting we recommend to use screw adhesive (medium strength). Subsequently, connect one cable of the speedometer sensor with +12 V ("switched plus") and the other one with the orange cable of the motoscope. Polarity is not relevant.

If your vehicle provides an original speedometer sensor output that gives a +12V output signal connect the white cable of the *motoscope mini* directly to this output.

Attention! *If one end of the delivered speedometer sensor is connected with +12V and the other open end touching vehicle earth accidentally, the sensor will be destroyed.*

Attention! *The magnet will defective, if it is exposed temperatures higher than 100°C or 212°F (i.e. hot brakes).*

10 Putting the instrument into the initial operation phase

Once all parts are installed securely and all cables are connected properly re-connect the battery and switch on the ignition or voltage supply. If the electrical connection is correct, the start display "motogadget" will appear. After this, the display will switch automatically to the speed indication. If this doesn't happen, turn off the ignition immediately and re-check all connection terminals and cables on the instrument systematically.

11 Operation and use of the instrument

11.1 General operation instructions

All operations of the instrument are carried out by one pushbutton. For programming the instrument pushing time of the button has to be varied in order to reach different displays modes and levels. Generally, three stages of control are distinguished, which can be differentiated optically by different ranges of flashing LEDs in the LED band.

Stage 1:	< 1 sec	[1/3 of the LED band is flashing]
Stage 2:	1 sec – 3 sec	[2/3 of the LED band is flashing]
Stage 3:	> 3 sec	[the whole LED band is flashing]

Please find the correct sequences for all setup functions in the flow chart in the appendix.

11.2 LED indications

11.2.1 Rev. counter indications in rpm by the LED band

The engine speed is indicated graphically by a yellow LED band in a range between 0 – 14.000 rpm depending on the version of your instrument housing (8K, 10K, 14K).

11.2.2 The adjusted revs. limit ("red area")

The first LED on the left side of the LED band is an **ultra-bright red LED** that starts flashing whenever the adjusted value of the engine speed reaches its critical level. Therefore, the red LED indicates the "red area". Furthermore, the BAR/ON/OFF-option can be chosen in the set-up. If this option is switched "ON" the whole LED band left of the critical engine speed starts flashing (see chapter 12.5 "FLASH").

11.3 The LCD display

11.3.1 Selection of different indications

After switching on the instrument the rev. counter band flashes immediately from zero to its maximum value and the indication "*motogadget*" appears on the main display for a short period of time. Subsequently, the standard display (speed indication) is called up automatically. From here it is possible to

switch to other indications and measurements by pressing the push button for less than 1 second (1/3 of the LED band must flash).

11.3.2 The speed indication (in mph or km/h)

The current speed of the vehicle is indicated by numbers in the speed indication's display (standard display). The indication is in a range between 0 and 350 mph or km/h. Weather mph or km/h shall be indicated can be adjusted in the set-up menu within the sub-menu PARAM/TACHO (see 12.4).

11.3.3 The daily-odometer-counter (mi or km)

This indication shows and stores the current distance covered. The daily-odometer-counter has a measuring range between 0 and 999,99 mi and km. Then it starts again with 0 mi or km. Current measures get permanently stored during the ride. In order to obtain a correct measurement the daily-odometer-counter should be reset before starting a new tour.

11.3.4 The total-odometer-reading (mi or km)

The total-odometer-reading shows all distances covered (mi or km) since putting the *motoscope light* in operation for the first time. The total-odometer-reading can only be reset to zero in the set-up (see sub-menu RESET. Furthermore, this value can get adjusted in the set-up.

11.3.5 Time counter for the current ride (hh:mm:ss)

The time counter for the current ride (stop-watch) measures the real riding time because the counting stops when the vehicle stands idle. The riding time is recorded second-precisely until 99 hours, 59 minutes and 59 seconds are reached. After turning off the instrument, the recorded time remains stored. This value can be reset any time.

11.3.6 Vehicle system voltage (V)

This value shows the current vehicle system voltage in a range between 9,0V to 18V.

11.3.7 Current acceleration (m/s²)

This value shows the current acceleration in a range of -15,0 m/s² to +15,0 m/s². Negative values are generated during braking. All maximum values get stored automatically.

11.3.8 Speed average (mph or km/h)

This value shows the average speed of all rides since the value was reset to zero in a range between 0 mph and 350 mph (or km/h).

11.3.9 Indication of rev./min on the LCD (rpm)

This value shows the current engine speed as numbers on the LCD display in a range between 0 and 14.000 rpm. This indication is less readable during a real ride compared to the LED band, but the shown values are more precisely (e.g. for tuning the ignition system etc.).

11.3.10 Time counting from 0-100 km/h or 0-60 mph (sec)

This indication shows the time given in seconds needed for an acceleration from 0 to 100 km/h (or 60 mph). In order to carry out such a measurement a small square, four horizontal lines, and an "s" for seconds have to be indicated on the display. The small square is only indicated, if the current speed is 0 mph (or km/h). If the display shows an old measure instead of four horizontal lines, this measure has to be deleted by pressing the push button for > 1 and < 3 sec (two segments of the LED band have to flash before releasing the push button). Now, the instrument is tuned for a new acceleration measurement.

11.3.11 Storing of maximum speed (mph or km/h)

This function stores and shows the maximum speed ever reached until it is reset to zero.

11.3.12 Storing of maximum rev./min (in rpm)

This function stores and shows the maximum engine speed ever reached until it is reset to zero.

11.3.13 Maximum acceleration (m/s²)

This function stores and shows the maximum positive acceleration ever reached until it is reset to zero.

11.3.14 Maximum deceleration (brake test) (m/s²)

This function stores and shows the maximum deceleration ever reached until it is reset to zero (e.g. for brake tests).

11.3.15 The gear position indicator (default setting is "off")

The gear position indicator announces the gear engaged currently. In order to get a correct announcement, the gear position indicator has to be activated within the set-up under **MENUE**, sub-period **GEAR**. Subsequently, the "learning" function for the respective gear ratios has to be executed (see set-up, sub-period **PARAM**, sub-period **GR TEACH**). Within **GR TEACH** the correct gear positions get calculated by measuring the current driving speed in relation to the engine speed. Thus, no further sensors or connecting cables are needed. That means, the instrument has to "learn" these ratios by engaging the mentioned "learning" function.

The gear position indicator announces the gear engaged currently as a number of 1 to 6. The numbers are displayed left to the speed indication in the standard display.

If the instrument receives no signal from the speedometer the gear position indicator cannot provide any results. During this stage it is also not possible to display whether the neutral gear or already another gear is engaged. Therefore, no number is shown on the display. If the instrument has too few information in order to process this data a small four-sided figure appears on the display for a short period of time. For more details see, chapter 12.4.

11.4 Resetting of measurements

The daily-odometer reading, the current distance covered, the time for the current ride, the average speed, the time counting from 0-100 km/h as well as all maximum values can be reset to zero. In order to delete a measurement navigate to the corresponding display by pressing the push button for less than one second. If the correct display shows up press the push button until 2/3 of the LED band is flashing (> 1 < 3 sec.). After releasing the push button the current value is reset.

12 The Set-up

All operations, adjustments, and calibrations of the *motoscope light* are carried out with only one push button. In order to go to the set-up you have to press the pushbutton until all three segments of the LED band flash (>3 sec). After releasing the push button the first sub-period **MENUE** appears on the display. By pressing the push button for less than 1 second (1 segment flashes) you can go to all other sub-periods (**LED**, **LCD**, **PARAM**, **FLASH** and **RESET**). If you want to escape from the set-up press the push button for > 3 seconds. Please employ the overview diagram in the appendix for the selection of all the following sub-periods.

12.1 The sub-period MENUE

Within the sub-period **MENUE** it can be determined whether or not a prevailing measure shall be indicated on the display. In order to go from one sub point to the other push the button for a short time (< 1 second). Adjustments can be altered by pressing the push button for medium time (> 1 < 3 seconds). After releasing the button a small rectangle appears on the display. Now it is possible to adjust the corresponding indication either "on" or "off" (see appendix). The default value for all functions is 'on', with one exception for the gear position indicator ("off").

The following functions can be altered: **SPD**, **ODO1**, **ODO2**, **TIME**, **VOLT**, **ACC1**, **÷ SPD**, **REVC**, **ACC2**, **▲SPD**, **▲REV**, **▲ACC**, **▲DEC**, **GEAR**.

In order to leave the adjusting modes the push button has to be pressed until 2 segments of the rev. counter scale have flashed (> 1 < 3 seconds). In order to go back to **MENUE**, push the key button again until all 3 segments have flashed (then let off).

12.2 The sub-period LED

Within this sub-period the brightness of the LEDs and the sensitivity of the automatic brightness control can be adjusted (**BRIG**). The brightness can be regulated in steps from 1 to 7. In the mode "**aut**" the brightness will be adjusted automatically according to the brightness of the surrounding area.

The sub-period **INDEX** facilitates the adjustment of the sensitivity of the automatic brightness control. The adjustment is also indicated by figures between 1 and 8. These factors control the brightness of the LEDs in regard to the brightness of the surrounding area. In this mode the maximum and minimum values of brightness will not be altered but the threshold values of their adjustment.

12.3 The sub-period LCD

Within this sub-period the brightness (**BRIG**) and contrast (**CONT**) of the LC-display can be adjusted. The values are given in per cent and have defaults of 99% **BRIG** and 80% **CONT**.

Attention! If the value **CONT** gets altered and the indications in the LCD disappear, the push button (time step 1) simply has to be continually engaged until the indications appear again.

12.4 The sub-period PARAM

Attention: Within this sub-period you have to enter all specific data of your vehicle into the micro processor of the instrument, which must to be carried out with greatest care.

The value **CIRC** represents the circumference of the wheel from which the speedometer sensor takes its impulses. **Attention: The wheel circumference has to be entered in cm!**

The value **ImpW** represents the number of transmitted impulses per wheel turn. If the *motogadget* speedometer sensor and one magnet is used the corresponding value is one, which is the default adjustment. If the original speedometer sensor of the vehicle is used, the number of impulses per wheel turn must be determined correctly and the determined value must be entered.

With regard to the wheel circumference (**CIRC**) and the impulses per wheel revolution (**ImpW**) the *motoscope light* determines the current speed and almost all other measures.

Consequently, you have to ensure that best care is taken in entering the necessary data. Please, double check the correctness and plausibility of the entered data and the indicated values of vehicle speed subsequently to entering of the relevant data, particularly before taking part in public traffic! If the entered data or the procedure of entering is wrong, the resulting measurements of the instrument also have to be wrong!

The function **ImpE** sets the calibration of the rev. counter by entering the number of ignition impulses generated per crankshaft turn. This value can depend on the number of cylinders, the engine construction and/or the type of ignition (e.g. lost spark or not). If the entered factor is incorrect, the engine speed displayed is usually either half or double the true value. If your vehicle has several ignition coils only the impulses from one coil are relevant, namely the coil to which the yellow signal cable is attached. Possible values range from 0.25 to 9 impulses. If "10" is reached, the **ImpE** value starts again at 0.25. In order to set the value engage the pushbutton for a short time (< 1 sec). To leave the menu engage the button until 2/3 of the LED band appear.

Example of use: A single-cylinder four-stroke engine with one ignition coil = one ignition impulse at 2 crankshaft turns. The resulting value to be entered would be 0.5.

Within the function **TACHO** it is possible to adjust the device in order to show miles ("mi") or kilometres ("km") on the display.

The function **SCAL** makes it possible to adjust different ranges of rev./min on the LED band and the LC display. Scales of 8.000, 10.000 and 14.000 rev./min are adjustable. Please compare the adjustment with the scale engraved into the housing of your instrument.

The function **ImpF** (impulse filter) offers a choice of four filters - A, B, C or D - for the engine speed indication. If the engine speed indication does not work satisfactorily with the factory-set filter B, please try one of the other filters.

The function **AUTO** can be set "OFF" or "ON". The "ON" mode activates an automatic operation that puts the different displays (values) back to the standard display (speed indication) after a short period of time (approx. 10 sec.).

The function **GR TEACH** represents the "learning" function for the gear position indicator :

1. Call up the set-up with the push button. 2. Activate the gear position indicator in the set-up under **MENUE**, sub-period **GEAR** (off/on→"ON".) 3. Go back to **MENUE** and navigate to **PARAM**. 4. Go to sub-period **GR TEACH**. Here the learning function **GR TEACH** can be activated by means of 2 flashing segments of the rev. counter scale.

The "learning" procedure starts with the 1st gear. At first, **G1** appears in the display and two small arrows flash. After breaking-in the first gear (see below) the procedure has to continued gradually with the following gears, up to max. **G6**.

As long as the two arrows flash (time is not limited), the countdown can be activated. Please take your time, because the learning function starts only after the countdown becomes activated manually.

If you are ready to ride your bike, start the engine and ride in the first gear. **Important:** at this stage the indicated gear must be engaged and must not be shifted! You also must not operate the clutch! Ride normally in the respective gear and push the button in order to start the countdown. The number 30 (seconds) appears on the display and starts counting down to 0.

Ride normally in the respective gear at an engine speed of approx. $\frac{1}{4}$ of the rev. counter scale. Then accelerate carefully to approx. $\frac{3}{4}$ of the counter scale and brake subsequently with the front wheel brake until $\frac{1}{4}$ of the rev. counter scale is reached. With this procedure tolerances, as load condition reactions, slip, and so on, shall be determined. **Please, take into account:** if the rear wheel has wheel spin or the front wheel locks, the measuring is distorted and must be started from the very beginning. If this should happen press the pushbutton again, still during the current countdown. With that, you jump back to the standard display from where you have to start the whole procedure completely new. For this reason it is very important to be carefully during acceleration and braking. Repeat acceleration and braking during the countdown and drive normally for the last 10 seconds till the countdown is finished. After that, choose the next higher gear and ride in this gear. **Then (not earlier!)** push the button again, in order to start the measuring countdown for this gear. Repeat this procedure in the same way until all gears are defined. If you have less than 6 gears, interrupt the measuring for the not required gear (e.g. G6) by pushing the button once more. Do this during the 30 seconds countdown runs down for this gear.

All "learning" events for the gear position indicator function must be carried out after each other. Single gears cannot be defined separately. However, you have all the time you need for defining each gear, because it depends only on triggering the respective countdown for each gear. That means, you should wait starting the countdown until the riding situation makes it sensible to record the measurements for the respective gear.

If you have finished all steps test the display for correctness. In very small limits it might be possible, that a wrong gear could be shown on the display for a short time. If the result of the test altogether shouldn't agree, the "learning" process must be repeated.

The "training of gears" should not be carried out in public traffic and all corresponding measurements are definitively carried out at own risk.

As the last sub-period under **PARAM** the version number of the software appears, indicated as **V** (e.g. V1.08). You cannot carry out any adjusting here but at support enquiries this detail can be important.

12.5 The sub-period FLASH

A threshold value (**TH**) for engine speed can be set within the sub-period **Flash**. The setting is used for the adjustment of the engine's rev. limit ("red area") and/or the gear shift light. In the default adjustment the ultra-bright LED on the left side of the LED band indicates the entered threshold value by flashing red. It is also possible to choose the option **BAR** (on/off). If this option is switched "on" the whole LED band left of the adjusted engine speed starts flashing. The default adjustment is "off".

In order to select individual digits in the **TH** function representing the desired threshold engage the pushbutton for time stage 1 (one bar). In order to go to the next digit, engage the button for time stage 2 (2/3 of the LED band). In order to leave the level, operate the pushbutton for time stage 3 (3/3 of LED bar).

12.6 The sub-period RESET

Within the sub-period **RESET** some or all stored values can be reset either to zero or to their default values (function **ALL** or **DEFA**). If you enter "yes" within the option **ALL** all adjustments, stored values and readings, **including the total odometer reading**, will be reset to zero or to their standard default values!

If you choose "yes" within the option **DEFA** the altered adjustments and values get reset to their default standard values but the total odometer reading remains stored.

The adjustments (default values) are not stored until the set-up is left.

Within the sub-period **ODO2 set** the total mileage display (total odometer) can be adjusted. If you have selected this sub-period (see overview in the appendix), a six-digit number appears that can be adjusted to your desired value by means of the pushbutton (see flow chart in the appendix).

13 Cleaning of the instrument

Use only gentle, non-corrosive detergents and a soft cloth for cleaning the *motoscope light*. Avoid anything that might scratch the aluminium housing and the display surface. Should any scratching occur, we recommend special polishing pastes in order to remove them from the display. Such pastes can be found, for example, in equipment stores for mobile telephones. Furthermore, we suggest the use of silicon spray from time to time. This keeps the colour of the anodised housing fresh and protects the instrument from dirt.

14 Safety instructions

The *motoscope light* provides a lot of information at one time. Users consequently require a certain "training" period in order to recognise all the given information quickly and correctly. Please take this into account, particularly during your first rides with the *motoscope light* and do not distract yourself by watching the instrument in public traffic.

The user of the instrument is responsible for the correct entry of all relevant data as well as for the adjustment of the speedometer and all other functions. In particular, the fitting of the dry reed contact as well as the input of all calculation factors for speed determination, such as the wheel circumference and the triggered impulses per wheel revolution, must be set with great care. The user is also responsible for mounting the instrument, the sensors, and all other accessory parts to the vehicle correctly and securely.

15 Trouble shooting

15.1 After the installation

- switch the ignition/vehicle system voltage "ON" and "OFF" for some seconds
- check functions with the motor on and off
- vehicle battery should be charged sufficiently and the vehicle system voltage must be higher than 9 V
- check all cables, connections, and sensors for correct installation and good contacts
- check all cables, connections, and sensors for correct polarities and/or short-circuits
- make sure that your vehicle has an interference suppressed ignition system and interference suppressed spark plugs. In case of doubt ask your motorcycle dealer
- If the above-mentioned attempts do not help, switch OFF the ignition/voltage supply and separate the sensor cable, the push button cable, and the ignition impulse cable from the device. Then re-check the polarity and connect the voltage supply only
- Watch the instrument display for a correct indication of the standard display. If it does not appear, read the recommendations in section 15.2
- In case of a suspected software malfunction we suggest as a first step resetting all data to their default values.

15.2 Malfunctions in general

If the tips listed above do not help to solve the problem go to www.motogadget.de where you will find further information and advice under "support".

When contacting us directly make sure that you have your customer number (see invoice/bill), the series number of the device (shown on the back side of the instrument), the software version, the date of purchase, and your vehicle data (make, brand/model, year of construction, type of ignition, etc.).

The *motogadget* team wishes you pleasant and safe riding, and lots of fun with your new *motoscope light*.

16 Appendix

16.1 EG conformity explanation (CE)

EG conformity explanation

In accordance with EG guideline for EMV (89/336/EEC)

The manufacturer:

Wipfler Keller Stahl GbR
Simplonstr. 59
D 10245 Berlin

explains that the described device

Type: Multifunction display for motor vehicles
Brand: motoscope light

agrees with the regulations of following EG guidelines:

EMV, guideline 89/336/EEC
Low voltage guideline 73/23/EEC

Used norms and technical specifications:

- EN 50227:1997, tuner-amplifiers and switching components -- approximation sensors, direct current interfaces for approximation sensors and switch amplifiers
- EN 55022:1987, electromagnetic compatibility of facilities of information processing and communication technology, limiting values and measurement procedure for radio interferences of information technology facilities
- EN 60051-1:1998, direct seeming electrical gauges and accessories -- gauges with scale display-
Share 1: Definitions and general requirements for all parts of this norm

EG conformity explanation

In accordance with EG guideline for EMV (89/336/EEC)

The manufacturer:

Wipfler Keller Stahl GbR
Simplonstr. 59
D 10245 Berlin

explains that the described device

Type: control light panel unit
Brand: motosign

agrees with the regulations of following EG guidelines:

EMV, guideline 89/336/EEC

Used norms and technical specifications:

EN 55022:1987, electromagnetic compatibility of facilities of information processing and communication technology - limiting values and measurement procedure for radio interferences of information technology facilities

Berlin, 9-20-2003

Graduate Engineer (FH) Garrit Keller
Technical manager

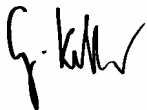

16.2 Terminal locations and colours of the connecting cables

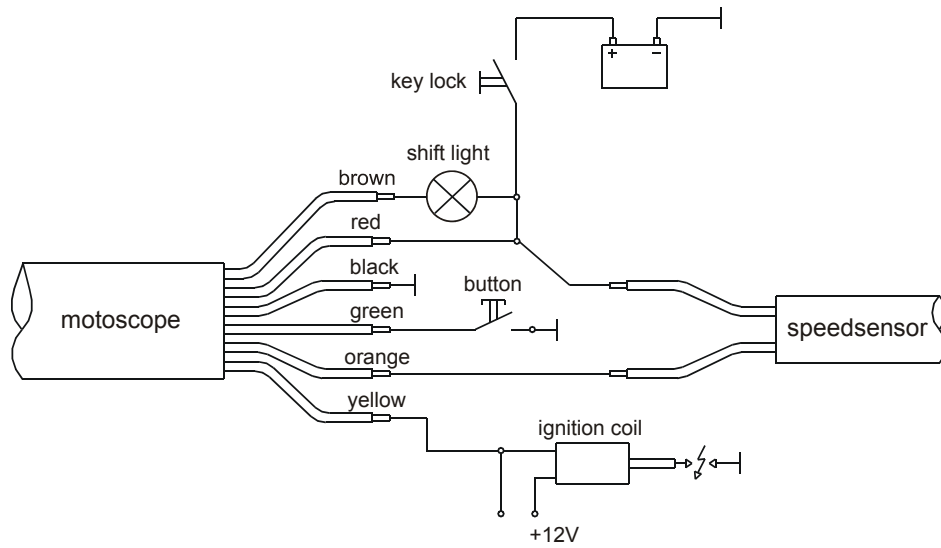

Remark: the gear shift light exit works only with the corresponding equipment with the correct poling. Our LED gear shift light has the following poling: core lead = plus, shielding = minus

16.3 Connection of the original speedometer sensor

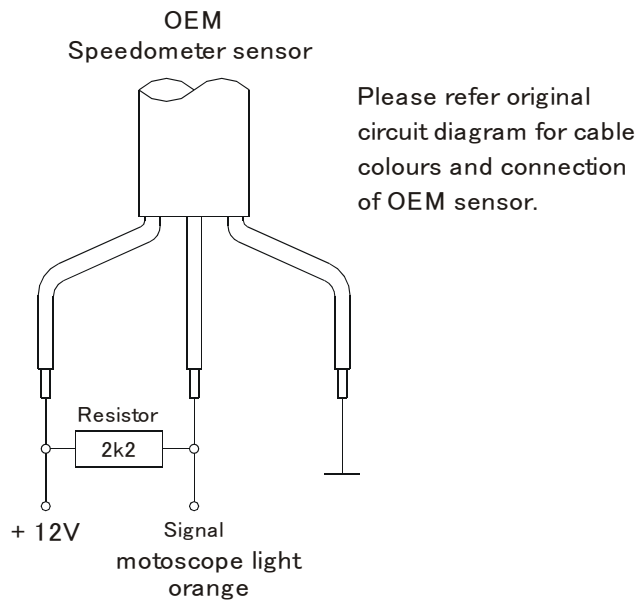

16.4 General overview of operations by using the pushbutton

